

# TYPICAL



## GC6716MD/HD/BD

SINGLE NEEDLE DIRECT DRIVE NEEDLE FEED LOCKSTITCH SEWING MACHINE

INSTRUCTION BOOK / PARTS CATALOGUE

### ※MAIN TECHNICAL DATA

Application	Common materials	Thick materials	Thick materials
Sewing speed	4500spm	3500spm	3000spm
Max. Stitch length	4 mm	5 mm	
Presser foot lifting height	6-11mm		
Rotating shuttle	Standard automatic oiling	Thick materials automatic oiling	Twice automatic oiling
Needle	DBx1 11#-16#	DP x5 18#-22#	

### 1.INSTALL THE MAGNET

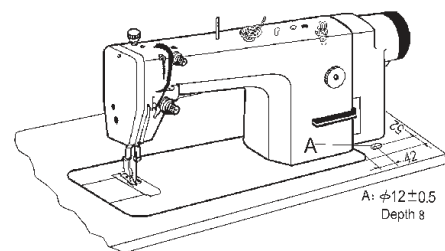

For safety, pedal should be no response when machine overturned. To realize it, a magnet with rubber cover installed into hole A. Note that S-plates must be upward.

### 3.ROTATING HOOK OIL AMOUNT ADJUSTMENT

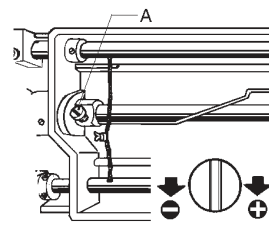

Adjust the oil amount of the rotating hook by turning the oil amount adjusting screw (A). Turn the screw (A) clockwise (in the "+" direction) to increase the oil amount; turn it counter-clockwise (in the "-" direction) to decrease the oil amount.

### 5.CONNECTION OF THE CLUTCH LEVER WITH THE PEDAL

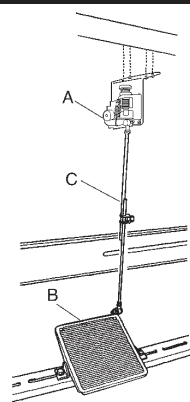

(1) Install speed governor A, link speed governor A and pedal B with tie bar, keep tie bar C vertical.  
(2) The optimum tilt angle of pedal is approximately 15 deg.

### 7.ADJUST THE PRESSURE OF PRESSER FOOT

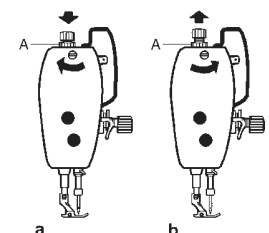

Pressure of the presser foot is adjusted in accordance with thickness of materials to be sewn.  
First loosen the lock nut (A), for heavy materials, turn the pressure regulating thumb screw as shown in Fig.(a) to increase the pressure, while for light materials, turn the pressure regulating thumb screw as shown in Fig.(b) to decrease the pressure, then tighten the lock nut (A).  
The pressure of the presser foot is recommended to be less as long as normal feeding is ensured.

### 2.MAXIMUM SPEED ADJUSTMENT

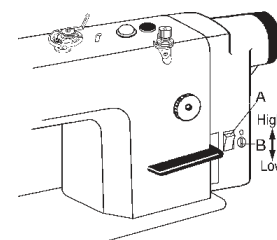

Push switch A, lighting lamp indicate power on. Turn the knob B to adjust the maximum speed, upwards to high and downwards to low.

### 4.NEEDLE INSTALLATION

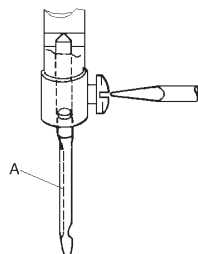

Turning the balance wheel to lift the needle bar to the upper end of its stroke. Loosen the needle clamp screw while keeping the long groove of the needle leftward, fully insert the needle shank up to the bottom of the needle socket, then tighten the needle clamp screw.  
Note: please take the drive in our motor cover accessory bag to operate.

### 6.ADJUST THE OPENING TIME OF THE TENSION DISCS

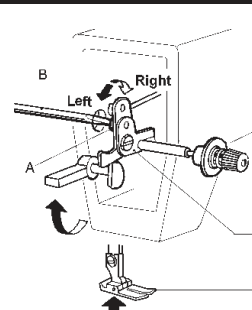

Within the presser foot lift range, the opening time of the tension discs can be adjusted as follows:  
(1) Remove the rubber plug from the back of the arm and Loosen the screw (A) of the knee lift level (left)  
(2) Move the tension releasing cam (D) leftward for earlier opening or rightward for later opening. It will facilitate the adjustment if putting a lifting high block under the presser foot lift.

### 8.ADJUSTMENT OF STITCH LENGTH AND REVERSE FEEDING

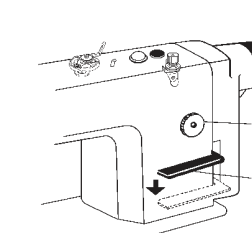

The stitch length can be adjusted by turning the dial knob (A). The figures on the face (B) of the dial show the stitch length in mm. The reverse feed level must be depressed by another hand while adjusting the stitch length (B). The reverse feeding start when the reverse feed lever (B) is depressed, the machine will feed forward again if the reverse feed level is released.

### 9.THREADING

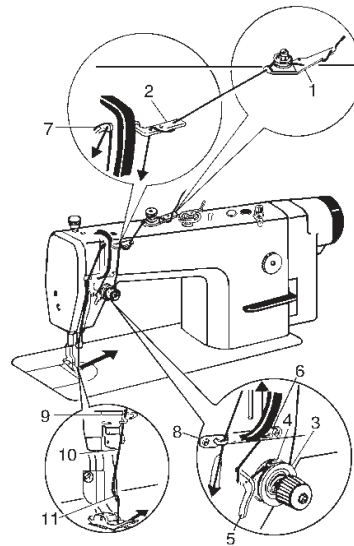

To thread the needle thread, raise the needle bar to the upper end of its stroke, lead the thread from the spool and perform Threading as shown in To draw the bobbin thread, hold the end of the needle thread and turn the balance wheel to lower the needle bar and then lift it to its highest position. Pull the ends of needle thread and bobbin thread forward under presser foot.

### 11.THREAD TENSION ADJUSTMENT

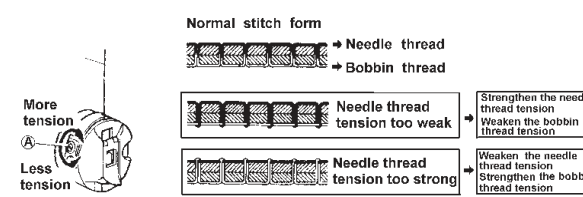

Thread tension should be determined in accordance with the stitch obtained by adjusting the tension of the bobbin thread and needle thread.  
The tension of the bobbin thread: to be adjusted by turning the tension spring regulating screw of the bobbin case. After adjusting, insert the bobbin into the bobbin case and hold the end of the thread from the bobbin case to hang the bobbin case, if the bobbin case falls slowly and evenly, the proper tension of the bobbin thread is obtained.  
The tension of needle thread: to be adjusted by turning the thumb nut.

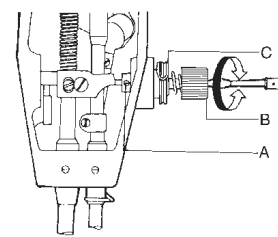

The stroke of the thread take-up spring runs from 6mm to 10mm, when sewing very thin fabrics, reduce the thread take-up spring tension and increase the thread take-up spring stroke, where as increase the thread take-up spring tension and reduce the thread take-up stroke when sewing very thick fabrics.  
Adjusting the thread take-up spring tension: First loosen the set screw (A), Turn the tension stud (B) counter-clockwise to decrease the tension of the thread take-up spring (C) to zero. Then turn the tension stud (B) clockwise till the spring (C) comes to the notch of the tension regulating bushing, and again turn the tension stud (B) half way back (counter clockwise). After the adjustment, tighten the set screw (A).  
Adjusting the thread take-up spring stroke: loosen the set screw (B) turn the stud (C) clockwise to increase the stroke or turn stud (C) counter-clockwise to decrease the stroke after the adjustment. Tighten the set screw (B).

### 12.ADJUST THE SYNCHRONIZATION OF THE NEEDLE WITH ROTATING HOOK

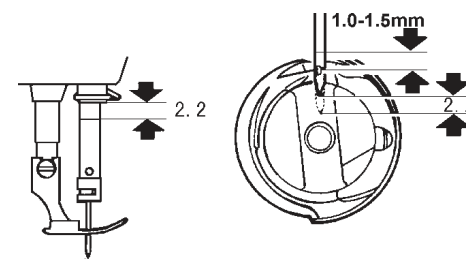

When lifting the needle bar from its lowest position of the stroke to the distance A, the hook point D of the bobbin should align with the center line of the needle and be 1.0-1.5 mm above upper end of the needle eye.

### 10.WINDING THE LOWER THREAD

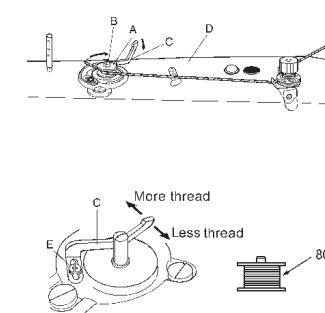

Turn on the power switch. Place the bobbin (A) onto the bobbin winder shaft (B). Wind the thread several times around the bobbin (A) in the direction indicated by the arrow. Push the bobbin presser arm (C) toward the bobbin (A). Raise the presser foot with the lifting lever. Depress the treadle. Lower thread winding will then start. Once winding of the lower thread is completed, the bobbin presser arm (C) will return automatically. After the thread has been wound on, remove the bobbin and cut the thread with the knife (D).

NOTE:  
1. Loosen the screw (E) and move the bobbin presser (C) to adjust the amount of thread wound onto the bobbin.  
2. The amount of thread wound onto the bobbin should be a maximum of 80% of the bobbin capacity.

### 14.STITCH LENGTH ERROR ADJUSTMENT

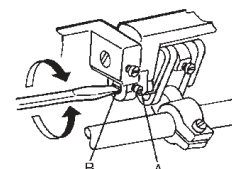

Loosen screw (A) to adjust the stitch length adjusting cam (B). Turn it rightward to narrow the stitch length as forward sewing, and widen it as reverse sewing; turn it leftward to widen the stitch length as forward sewing, and narrow it as reverse sewing.

### 15.FEED DOG HORI ONTALTY ADJUSTMENT

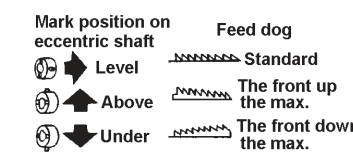

Heighten the front of feed dog to prevent fabric from wrinkling, lower the front of feed dog to prevent fabric from defection, breaking of hook thread.

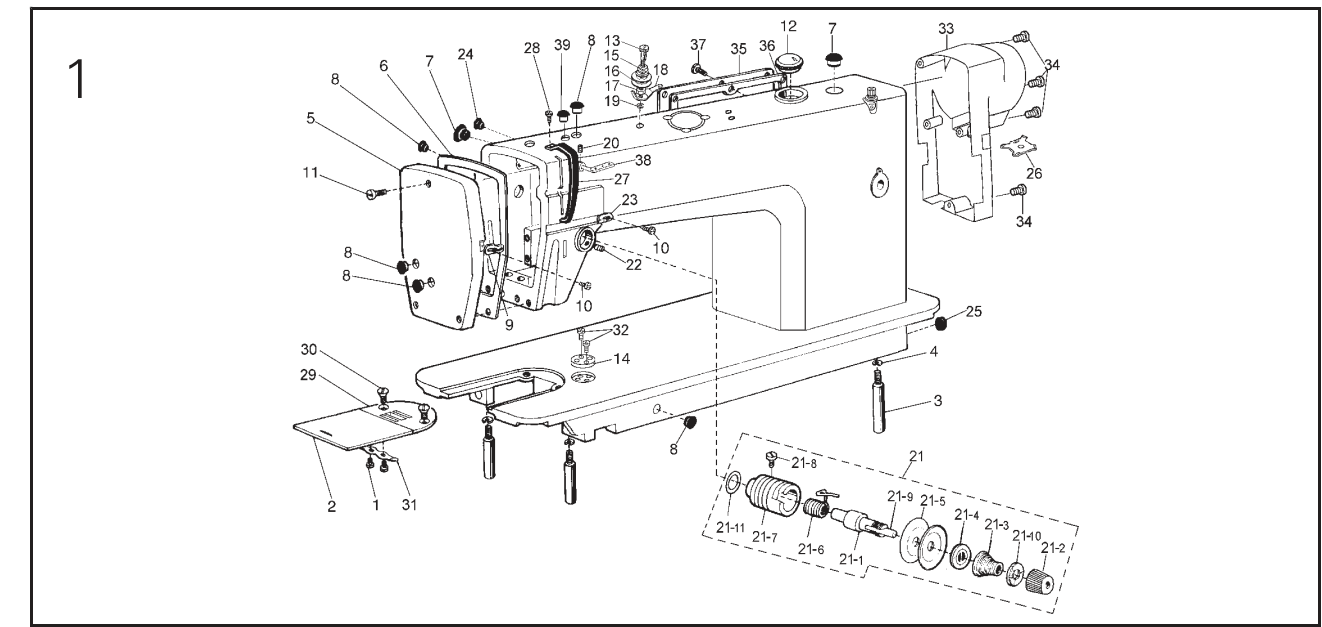

### 1.ARM AND BED MECHANISM

No.	Ref.No.	Description	Qt.		
			M	H	B
1	022170003	Screw	2	2	2
2	022170001	Slide plate	1	1	1
3	048100005	Leg	3	3	3
4	S150601004	Spring washer	3	3	3
5	027100002--V	Face plate	1	1	1
6	027100003	Face plate gasket	1	1	1
7	022130003--V	Rubber plug (Φ 19)	2	2	2
8	022130004--V	Rubber plug (Φ 11.8)	6	6	6
9	022130005	Thread guide on face plate	1	1	1
10	022130006	Screw	2	2	2
11	022100006	Screw	3	3	3
12	022180001--V	Oil check window	1	1	1
13	022150001	Screw	1	1	1
14	057100008	Ruler plate	1	1	1
15	022150002	Tension spring for pretension	1	1	1
16	022150003	Thread tension disc	1	1	1
17	022150004	Pretension thread guide pad	2	2	2
18	S150620001	Spacer	1	1	1
19	022150005	Pretension thread guide	1	1	1
20	124100006	Screw	1	1	1
21	124130000--V	Thread tension bracket assy	1	1	1
21-1	022160001	Thread tension stud	1	1	1
21-2	124130001--V	Thread tension nut	1	1	1
21-3	124130002	Thread tension spring	1	1	1
21-4	048110001	Thread tension spring	1	1	1
21-5	022160004	Thread tension releasing disc	1	1	1
21-6	022160005	Thread tension disc	2	2	2
21-7	022160006	Thread take-up spring	1	1	1
21-8	022160008	Screw	1	1	1
21-9	238100004	Thread tension releasing pin	1	1	1
21-10	022160010	Stop disc	1	1	1
21-11	022160011	O-type ring	1	1	1
22	022100013	Set screw	1	1	1
23	022100014	Thread guide	1	1	1
24	022100015--V	Rubber plug (Φ 8.8)	5	5	5
25	022100016	Rubber plug (Φ 27)	1	1	1
26	238100009	All purpose screwdriver	1	1	1
27	BXF9768001	Thread take-up lever guard	1	1	1
28	022200004	Screw	1	1	1
29	027100004	Needle plate	1	1	1
30	027100104	Needle plate	1	1	1
31	022100020	Screw	2	2	2
32	022170002	Slide plate spring	1	1	1
33	124100004	Screw	2	2	2
34	238C12000	Motor cover	1	1	1
35	B048509294	Screw M5x18	4	4	4
36	022140001	Slide plate	1	1	1
37	022140002	Washer	1	1	1
38	022100006	Screw	8	8	8
39	022100010	Thread guide	1	1	1
39	022100017--V	Rubber plug (Φ 5.7)	1	1	1

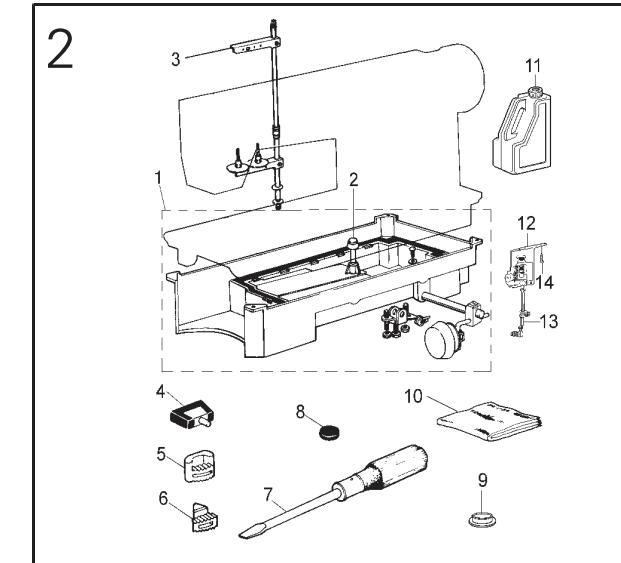

### 2.OIL RESERVOIR AND ACCESSORIES

No.	Ref.No.	Description	Qt.		
			M	H	B
1	036C10001	Oil reservoir asm	1	1	1
2	165F01001	Knee lifter lifting pin	1	1	1
3	006F00030--W	Thread spool asm	1	1	1
4	022990000	cushion	2	2	2
5	022900009--V	Cushion(B)	2	2	2
6	022900010--V	Cushion(S)	2	2	2
7	W060401017	Screw drive(long)	1	1	1
8	W050103001	Magnet block	1	1	1
9	238C00006	Magnets	1	1	1
10	W060302036	Machine head cover	1	1	1
11	0229900017	Oil tank	1	1	1
12	238C14000	Governor	1	1	1
13	238C15000	Rod complete	1	1	1
14	S150221002	Wood screw M5x12	4	4	4

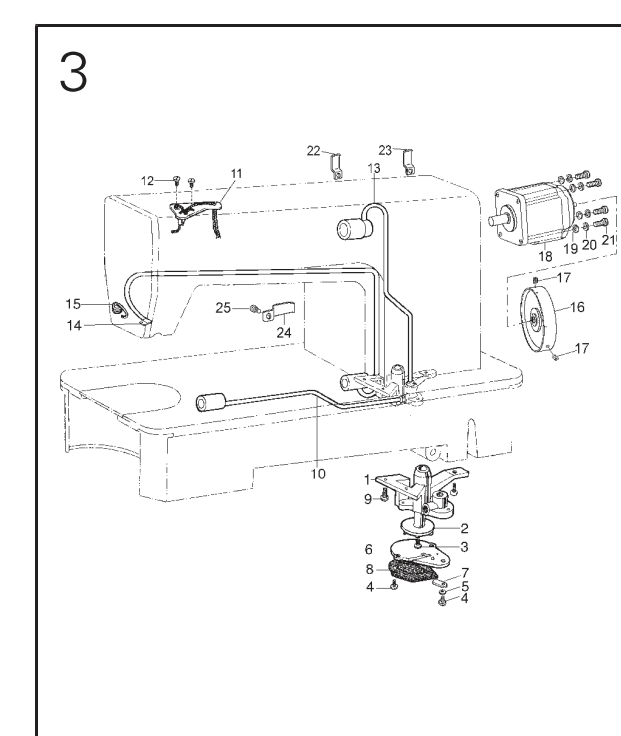

### 3.OIL PUMP AND MOTOR MECHANISM

No.	Ref.No.	Description	Qt.		
			M	H	B
1	022800001	Oil pump	1	1	1
2	022800002	Oil pump impeller	1	1	1
3	022800003	Screw	1	1	1
4	022800004	Screw	3	3	3
5	S150601003	Springee washer 3	1	1	1
6	022800006	Oil pump fitting	1	1	1
7	022800007	Oil adjusting plate	1	1	1
8	022810000	Oil pump screen	1	1	1
9	022800009	Screw	3	3	3
10	036A20N	Oil pump for hook	1	1	1
11	027811000	Oil braid fitting plate	1	1	1
12	022700015	Screw	2	2	2
13	022840N	Oil pump for arm	1	1	1
14	027800002	Oil return pipe	1	1	1
15	036A00002	Oil filter holder	1	1	1
16	238710001	Hand wheel	1	1	1
17	S150215001	Screw M5x8	2	2	2
18	257700001	Motor	1	1	1
19	B084050974	Flat Washer S5	4	4	4
20	B082050864	Spring Washer	4	4	4
21	B048509294	Screw M5x18	4	4	4
22	238C00008	Cord holder	1	1	1
23	238C00003	Cord holder	1	1	1
24	BXF8423009	Cord holder	1	1	1
25	022200019	Screw	1	1	1

XI'AN TYPICAL INDUSTRIES CO.,LTD.

Address: No.335 Taibai South Road,  
Xi'an, P.R.China-710068  
Tel: +86-29-88279091 88279150

Fax: +86-29-88249715 88245215  
E-mail: typical@chinatypical.com  
Http: www.chinatypical.com

